



SUPERSPORT BOAT MANUFACTURE.

STERK



sterk[sterk]

*adjective**

firm, sound, or powerful, and therefore not easily broken, destroyed, attacked, defeated, resisted, or affected by weariness, illness

*<https://dictionary.cambridge.org>

Supersport Boats are in our DNA.

Boat manufacturer Milan Sterk, designer Carlos Vidal, and naval architect Sasha Vlad turn visions into reality with **STERK**.

As a team with over 20 years of experience each in the maritime industry, the crew of boat-building enthusiasts, engineers and boat designers share the same STERK DNA - to simply build the best Supersport boats.

By choosing a production site in Germany, the STERK team pursues aspirations of minimal ecological impact, driven by the philosophy of sustainable progressive thinking. Short supply chains and high-quality standards are crucial for MS Marine GmbH. Together with great know-how, they form the basis for successful manufacturing of unique European Supersport boats.

STERK is the boat manufacturer for enthusiasts who love speed and comfort without compromise.

B1

#the_beauty_in_the_beast





Iconic Design

The **STERK 31** impresses with a Mediterranean inspired layout, state-of-the-art technology and perfect functionality. Of the three models on offer, STERK 31 RC is the first to be presented. A wet-bar version and full-cabin version will follow in 2023.

The boat shows greatness: a supersport hull form, a focused driving cockpit, a large 530 l (140 US.Gal) fuel tank, two generous sunbeds and an extra-large t-top are just a few highlights of the numerous unique features to be enjoyed. Fine details like our **seamless** hull-deck joining method emphasise **STERK** exclusivity and luxury engineering.

With up to 600 hp, the drive-by-wire interface ensures effortless, precise transmission and control of the powerful, sporty performance.

Manufactured in Germany.



B1

Radical



Shape of Speed.

Fine Tech.

The Supersport hull shape has been designed for fast running and agile response. It features a twin stepped deep V layout with strategically placed spray rails to enhance lift and reduce spray. Hundreds of hours by CFD testing resulted in exhilarating performance while maintaining a safe, predictable handling.

A novel feature unique to **STERK** are hooked rails on the aft planing surface. Combined with our negative chines, they provide great bite and less heel in fast turns and prevent spinout while evoking a great feeling of confidence synonymous with the **STERK** name.

Extremely stable and lightweight composite materials are handcrafted by our specialists in a completely new manufacturing facility. The **seamless** hull-deck joining method emphasise exclusivity and luxury engineering.

Cleanliness, high precision and meticulous quality controls ensure, that every **STERK 31** is a unique and durable masterpiece made in Germany.



STERK 31 Basic Highlights.



Impressive.

CECat.B = 6 Pax
CECat.C = 9 Pax
Fuel tank = 530 l (140 US.Gal)
Fresh water = 130 l (34 US.Gal)
Power max. = 2x300 hp
Total length = 9.73 m (32 ft)
Width = 2.99 m (9,8 ft)
Weight w/o engines = 2620 kg (5776 lbs)
Draft incl. engine = 0.84 m (2,8 ft)
Air draft incl. t-top = 2.4 m (7,9 ft)
Air draft excl. t-top = 1.87 m (6,2 ft)
v/Cruise = 30 knots (34 mph)
v/Max = ±60 knots (69 mph) (with 2x300 hp)

Digital next-generation electric system
Car-like cockpit and dashboard design
Two rotating pilot seats
Discreet stainless-steel handrails Triple
Bilge pump system
Private bathroom
Electric toilet with fresh water flush
Bathing ladder on port side platform
Retractable anchor arm
Rear sunbed with Silvertex cushions
Bow Seating with Silvertex cushions
Generous Sunbed of 5.5m² (59ft²)
Cup holders
Leather steering wheel
Premium materials used throughout



STERK
31
TUNING PACKAGES

31RC + 31WB

SILVER Package.

- Compass with backlight
- ZIP Wake automatic trim system
- 2 bathroom lights
- Bow sunbed extension with table leg
- Console cabin lights
- Cleats midship
- Bimini rear
- Black water system with 60 l black water tank
- Fresh water system with deck shower and 130 l water tank
- Hifi package with 2 loudspeakers
- 2 cabin reading lights only RC Version
- Navigation lights CE, BSH or preinstalled USCG
- ZIP Wake automatic trim system
- LED strip in rear cabin only RC version

GOLD Package.

- Bimini bow
- 1 pcs 52 l custom made fridge under the bench (max. 2 pcs possible or 1 pcs 52 l fridge and 1 pcs 52 l freezer as an option) only RC Version
- Q double 10" chartplotter with 4G modem, NMEA, Q App and remote control
- Bathroom with electric water closet and sink with faucet

PLATINUM Package.

- Cockpit lights
- 1 pcs cooled and heated cupholder (max. 3 possible)
- Individual colour of the hull 3M wrapping
- Anchor winch 800 W, 5 m galv. chain, 30 m rope, ss. 10 kg anchor, ss. Swivel
- PlasDeck ®
- Wireless phone charger and holder
- 4D sound upgrade to 4 loudspeakers, amplifier and subwoofer

ADDITIONAL Options.

- T-top with fibreglass top with LED downlight
- Fuel tank surcharge 530 l EPA, CE certified, preinstalled
- Boat cover

All data can differ +/-10%. Equipment is changeable without prior notice and does not represent any part of a contract concluded. Photos may show optional equipment.

The Captain`s Choice.

The base of the STERK 31 offers the future captain a variety of options to configure their boat according to their individual requirements.

For explorers and adventurers there is the REAR CABIN version with a well appointed 2 berth sleeping cabin and an additional sun deck for relaxing.

The WET BAR version caters to entertainers and is equipped with kitchen, bar and a super stylish lounge.

With many other options such as a t-top, various bimini configurations, wake-surf-ski tower and various packages from Silver to Platinum, the STERK 31 can be adapted to suit individual needs from sporty to comfortable.



BIMINI

Light & easy - ready for Adventure.





WET BAR
Cooking Lounge for Connoisseurs.



REAR CABIN
Cosy Room for Explorers.



WAKE TOWER
Made for Water Sports.



MOTOR
Up to 600 HP

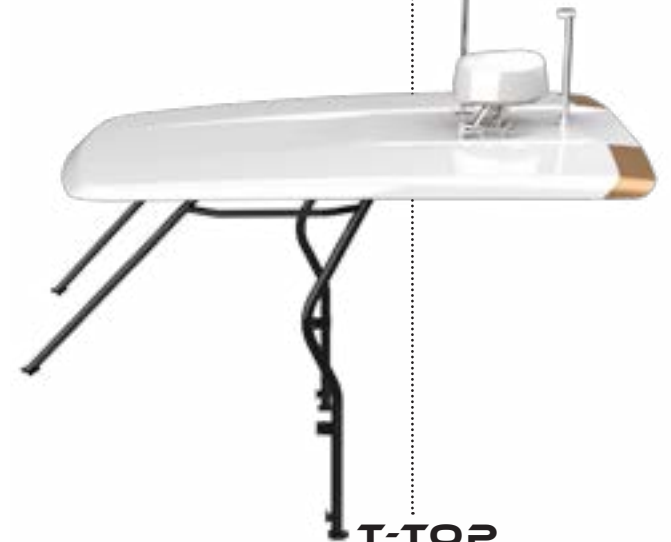

T-TOP
Technical Weather Shield.

31RC

Rear Cabin Sun Deck for Explorers.

For overnight trips, the RC version comes with a large sunbed and a cosy cabin with accommodation for 2 people.

A comfortable, private bathroom and large aft platform offer highest quality comfort during your nights on board, allowing you to just forget, relax and enjoy.

Up to 2 x 52 l fridges (or 1 x 52 l fridge and a 1 x 52 l freezer) and two possible dinettes provide great flexibility while spending several days on water.

SILVERTEX CABIN CUSHIONS.

**REAR CABIN (FOR 2)
UNDER REAR SUNBED.**





31WB

Wet Bar Lounge for Connoisseurs.



The WB version presents itself with a well-designed bar, dining lounge, and kitchen for wonderful moments with friends or family.

Comfortable bathroom, large aft platform, extra spacious sitting area, wet bar with refrigerator, and kitchenette will ensure maximum comfort during your stay on board.

**CONVERTIBLE REAR
LOUNGE AND SUNBED
MADE OF SILVERTEX CUSHIONS.**

FRIDGE. STOVE. SINK. BAR.



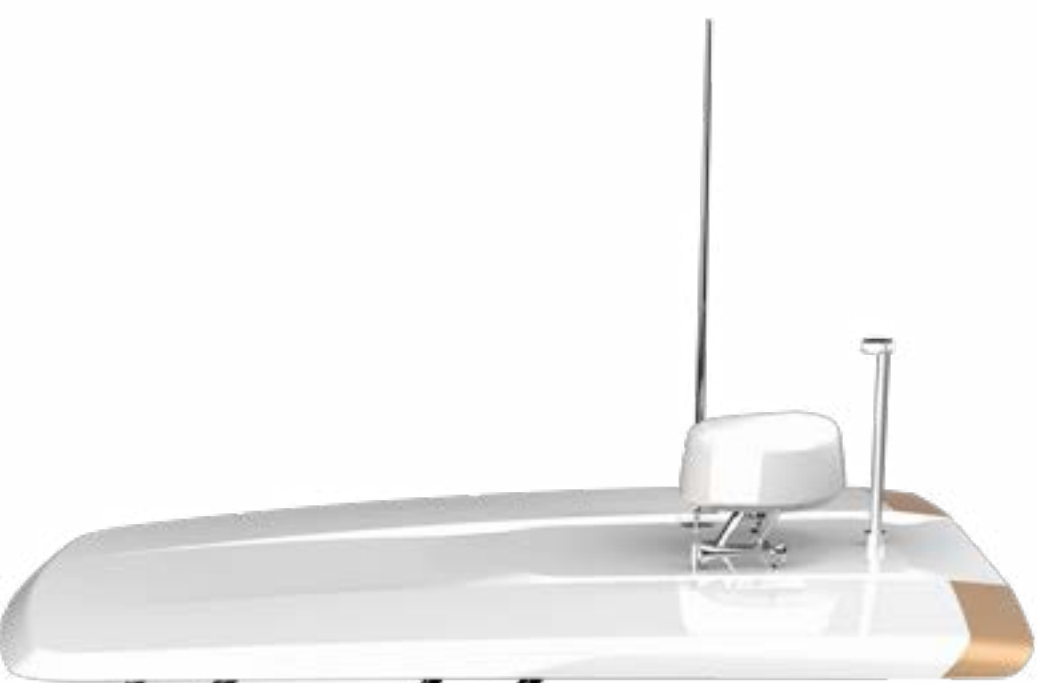

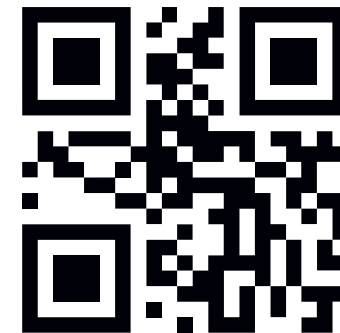

STERK

MS Marine GmbH
Gewerbegebiet Ost 31
92353 Postbauer-Heng Germany
Fon: +49/(0)9188/3079896
Fax: +49/(0)9188/3079897
Email: post@sterkyachts.com
Web: sterkyachts.com

Dealer: